

GRUPPO TESTA CON BRACCIO GIRAMATRICI  
 GROUPE DE LA TÊTE AVEC BRAS DE CINTRAGE  
 HEAD UNIT WITH DIE-TURNING ARM  
 KOPFEINHEIT MIT BIEGEARM

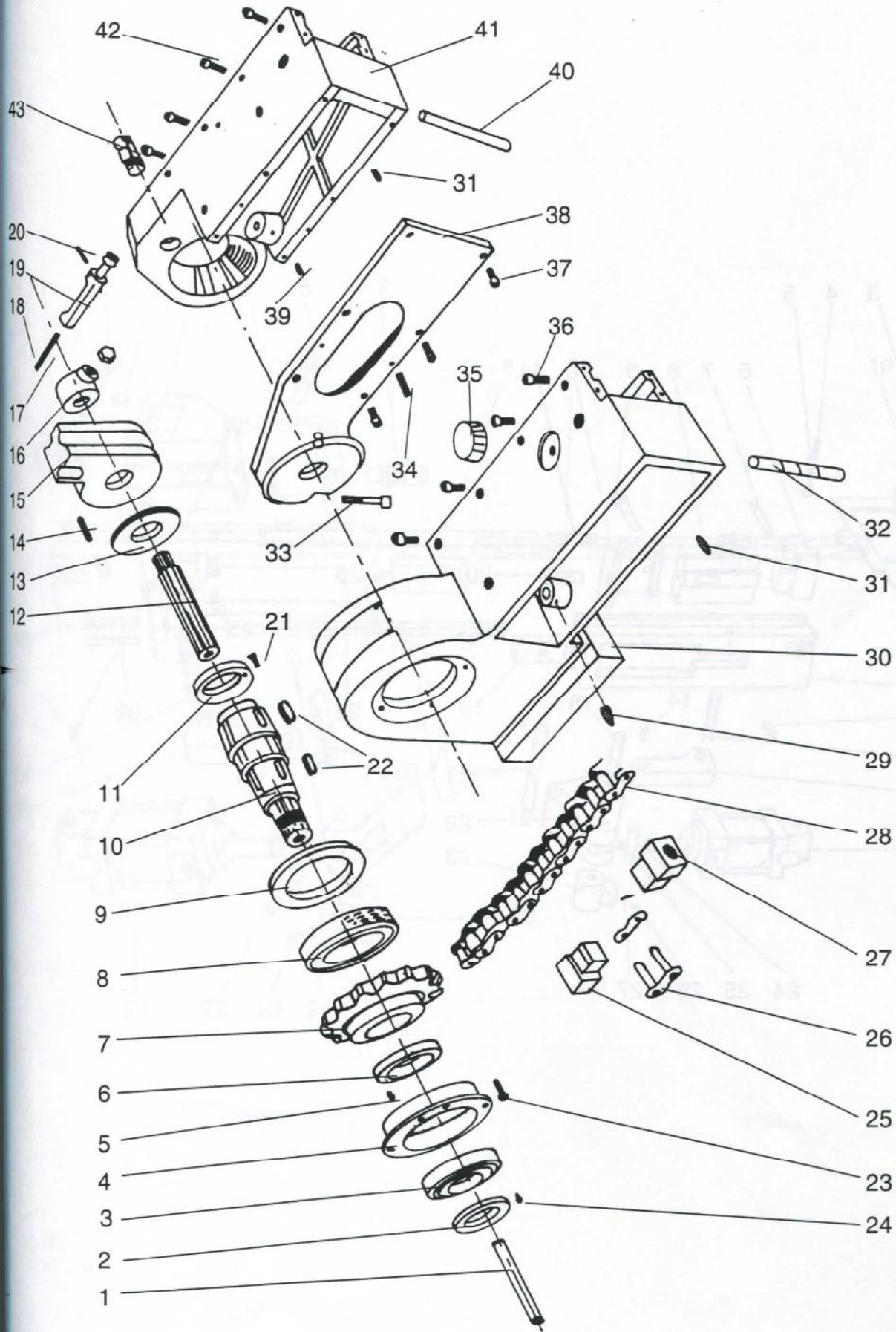

GRUPPO CARRELLO CONTROMATRICE  
 GROUPE DU CHARIOT COUSSINET  
 COUNTER-DIE CARRIAGE UNIT  
 EINHEIT DES GEGENMATRIZENSCHLITTENS

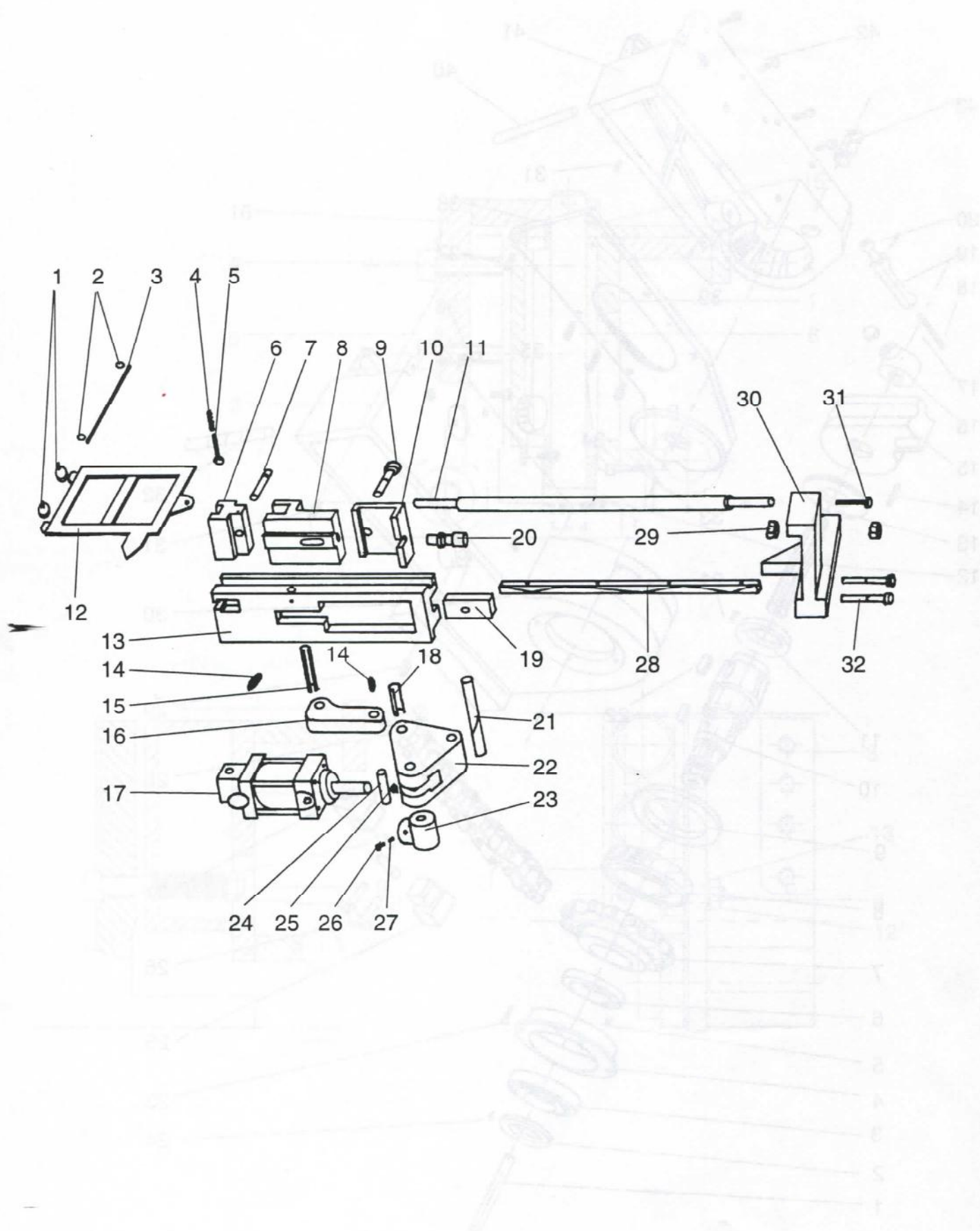



GRUPPO CARRELLO RULLI O SLITTO  
 GROUPE DU CHARIOT DES ROULEAUX OU GLISSIÈRE  
 ROLLER OR SLIDE CARRIAGE UNIT  
 EINHEIT DES ROLLENSCHLITTENS ODER DER GLEITSCHIENE

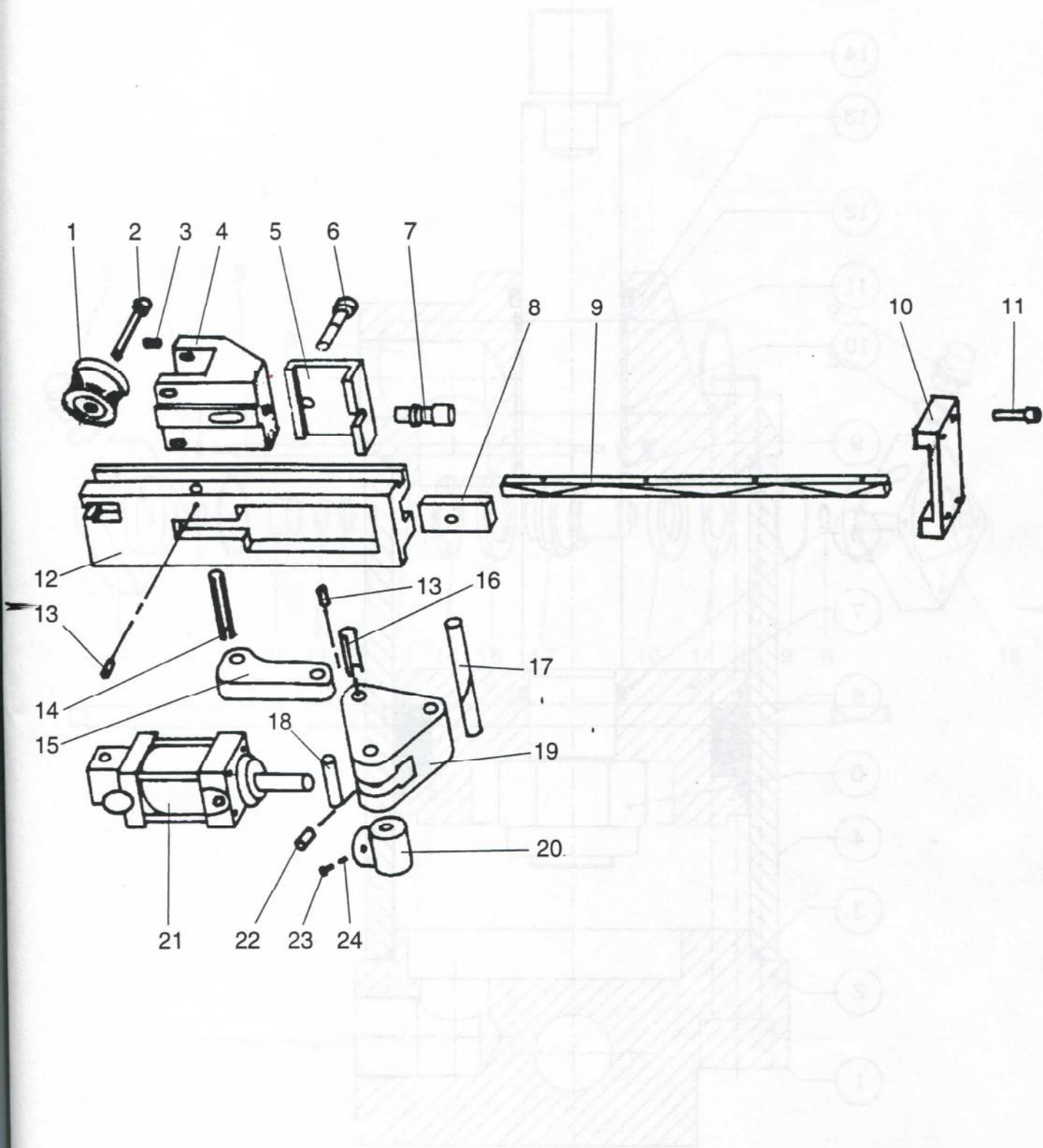

**GRUPPO CILINDRO BLOCCAGGIO CARRELLI**  
**GROUPE DU CYLINDRE DE BLOCAGE DES CHARIOTS**  
**CARRIAGE LOCKING CYLINDER UNIT**  
**EINHEIT DES ZYLINDERS ZUR SCHLITTENFESTSTELLUNG**

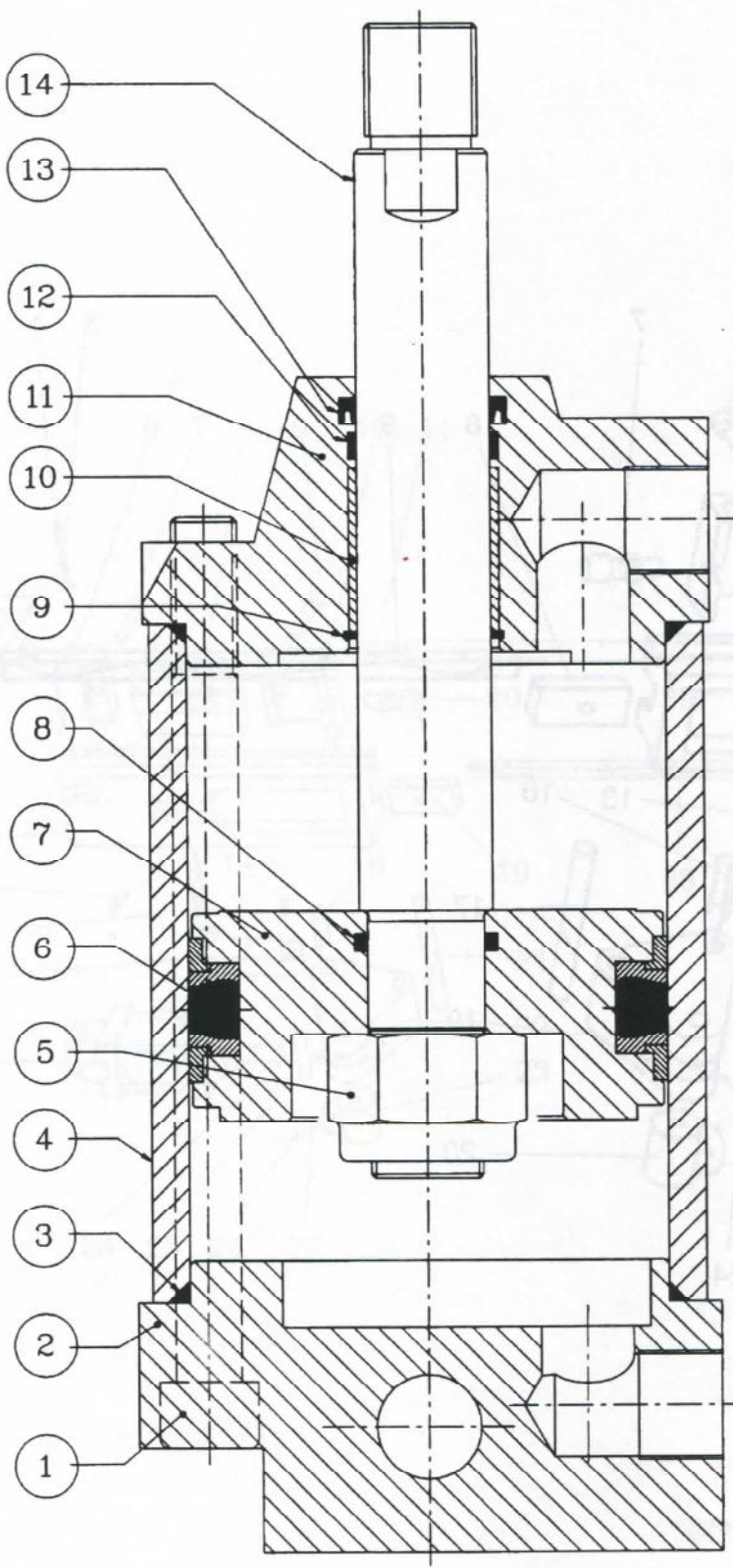



GRUPPO CILINDRO AZIONAMENTO BRACCIO GIRAMATRICI  
 GROUPE DU CYLINDRE DU BRAS DE CINTRAGE  
 DIE-TURNING ARM CYLINDER UNIT  
 EINHEIT DES ZYLINDERS DES BIEGEARMES

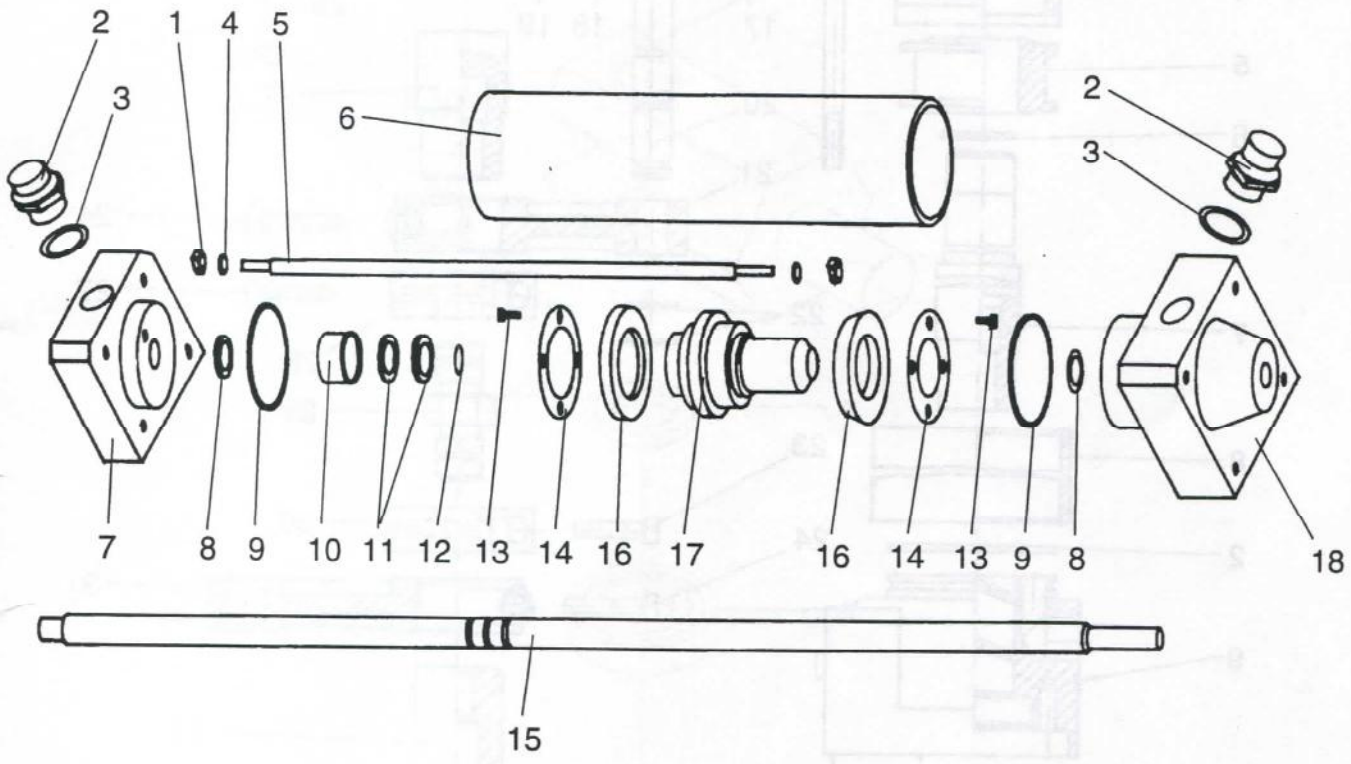

FRITZ GROSS GmbH  
 Werkzeugmaschinen  
 Karl-Benz-Straße 1  
 D-40764 Langenfeld / Rhld.  
 Tel. 0 21 73 / 85 04-0 • Fax 85 04-40  
 E-Mail: fritzgross@fritz-gross.de

GRUPPO CILINDRO ESTRAZIONE MANDRINO  
 GROUPE DU CYLINDRE D'EXTRACTION DU MANDRIN  
 MANDREL EXTRACTION CYLINDER UNIT  
 EINHEIT DES DORNAUSZUGSZYLINDERS

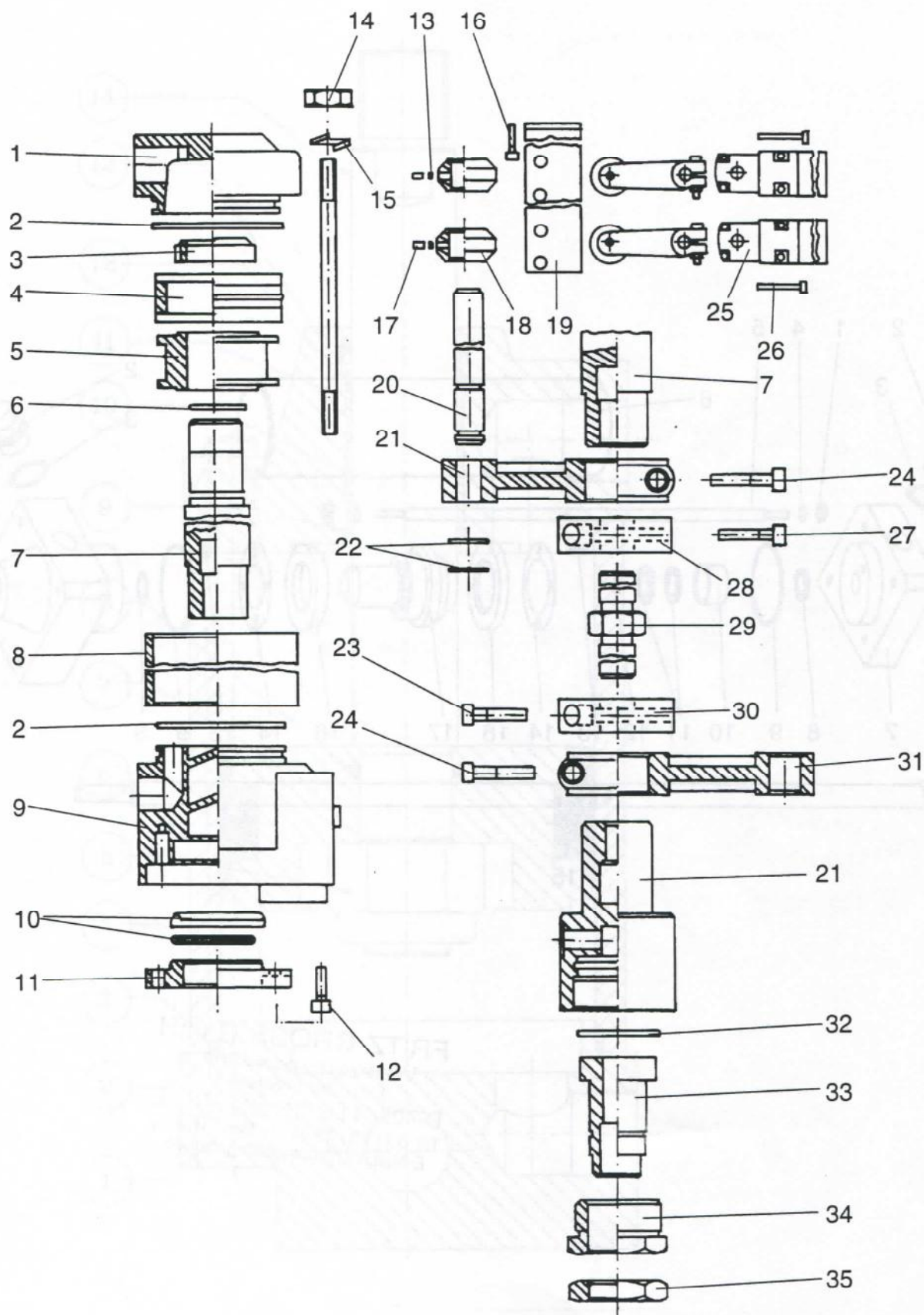

**GRUPPO CARRUCOLA RICHIAMO MATRICE**  
**GROUPE DE LA POULIE DE RAPPEL DE LA MATRICE**  
**DIE RETURN PULLEY UNIT**  
**EINHEIT DER UMLENKROLLE ZUM BIEGEFORMRÜCKZUG**

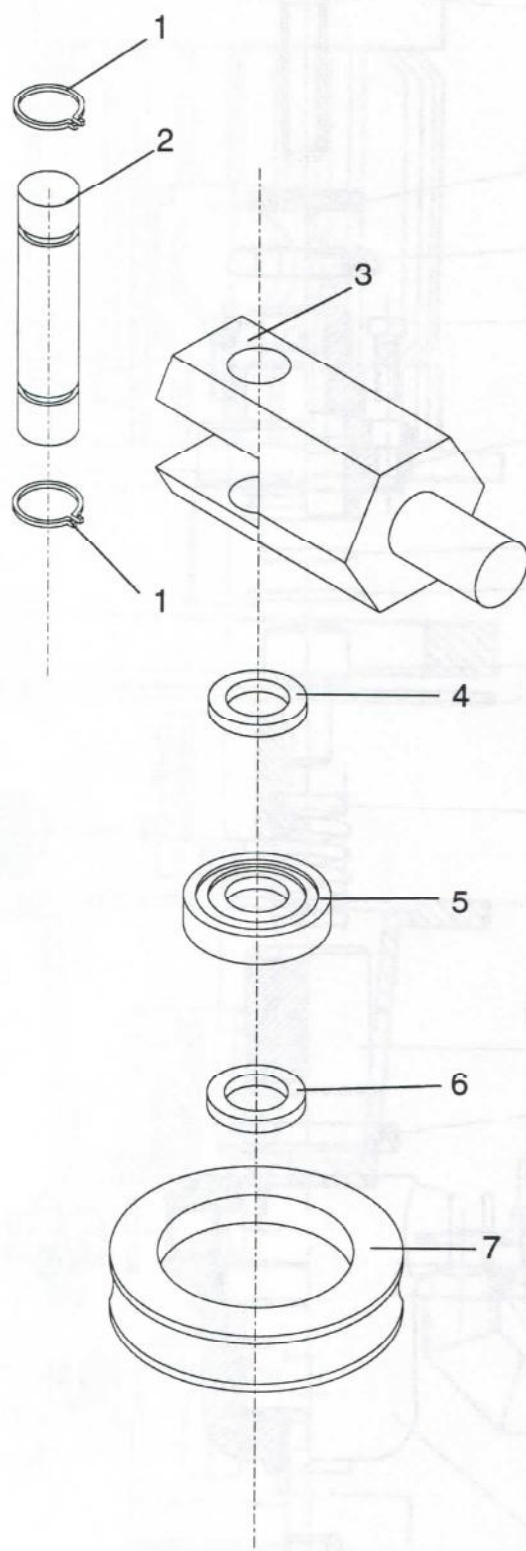



GRUPPO POMPA LUBRIFICAZIONE MANDRINO  
 GROUPE DE LA POMPE DE LUBRIFICATION DU MANDRIN  
 MANDREL LUBRICATION PUMP UNIT  
 EINHEIT DER DORNSCHMIERPUMPE

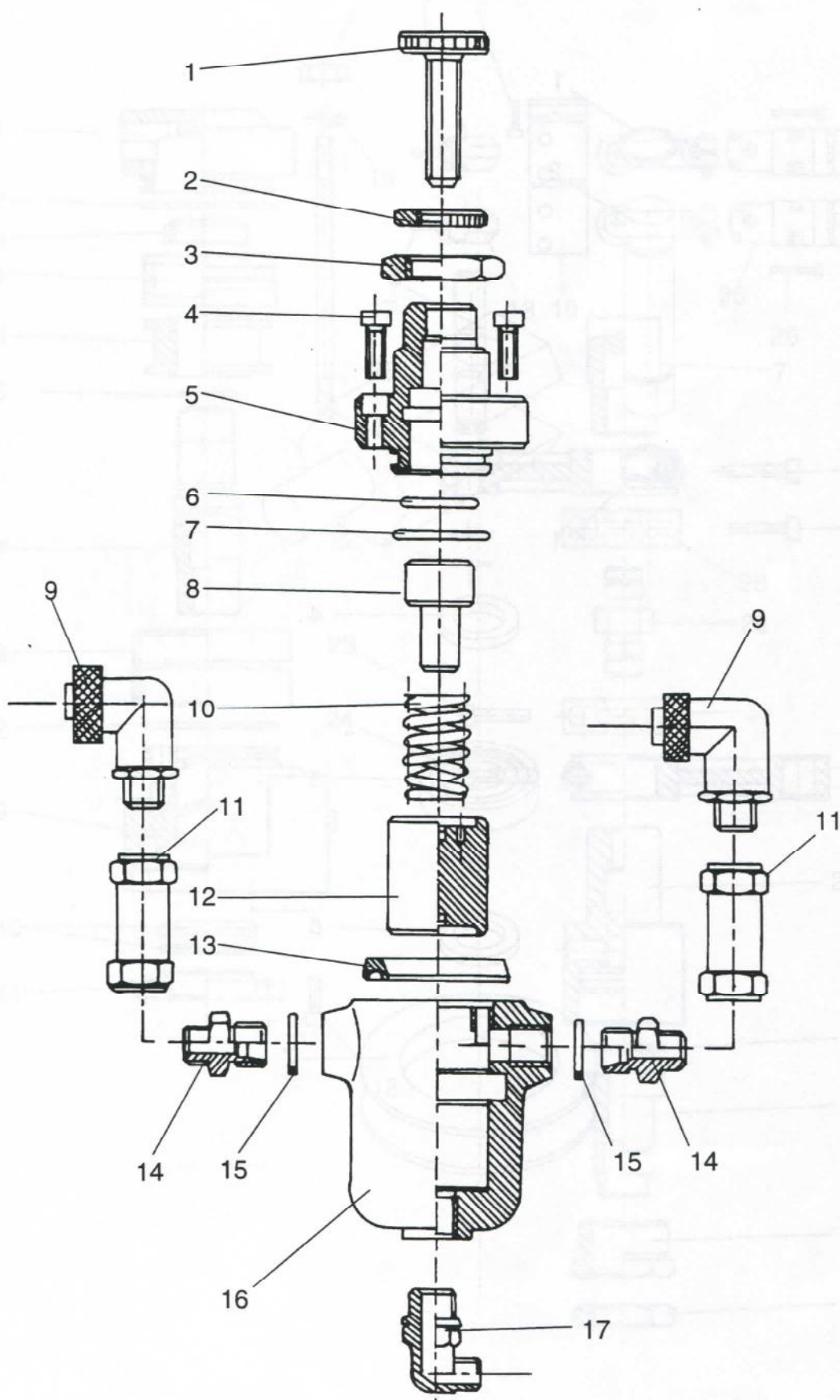



GRUPPO MOTORE ELETTRICO-GIUNTO DI TRASMISSIONE-POMPA IDRAULICA FILTRO  
 GROUPE DU MOTEUR-JOINT-POMPE HYDRAULIQUE-FILTRE  
 MOTOR - COUPLING - HYDRAULIC PUMP - FILTER UNIT  
 EINHEIT MOTOR - KUPPLUNG - HYDRAULIKPUMPE - FILTER

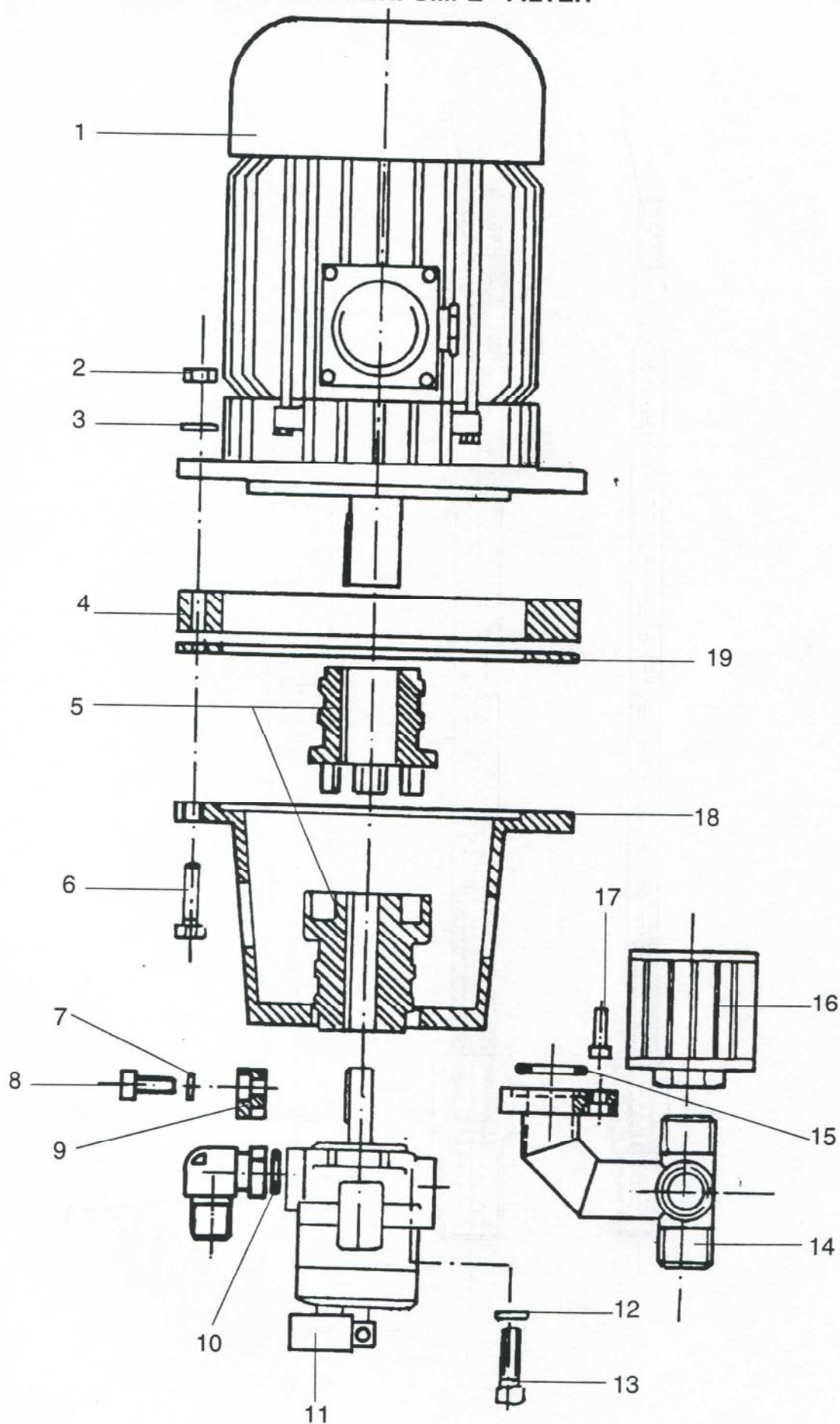

ASTE PORTA MANDRINO  
TIGES PORTE-MANDRIN  
MANDREL CARRIER RODS  
DORNSTANGEN

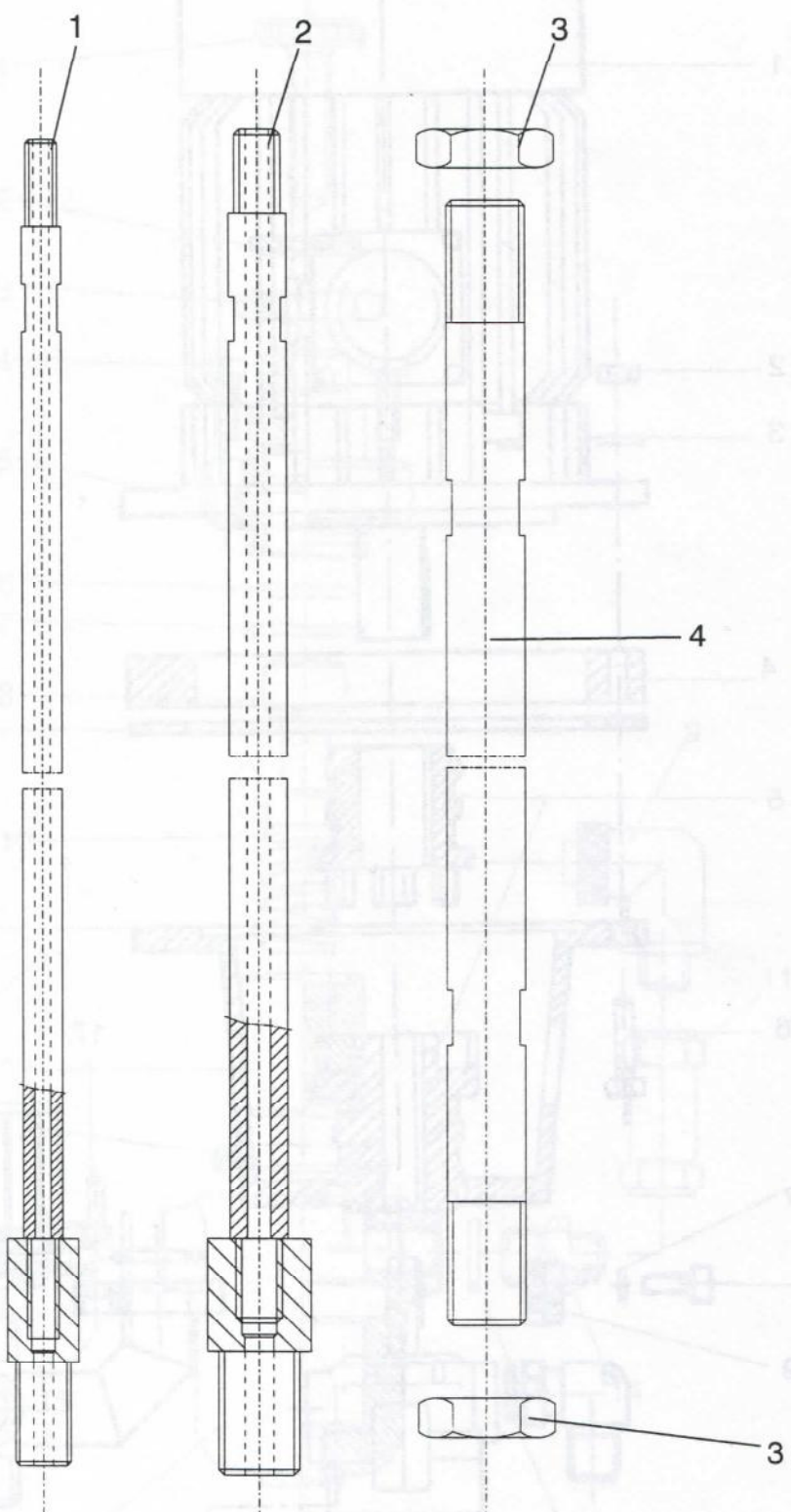



**GRUPPO CARRO POSIZIONATORE**  
**GROUPE DU CHARIOT POSITIONNEUR**  
**POSITIONING CARRIAGE UNIT**  
**EINHEIT DES POSITIONIERSCHLITTENS**

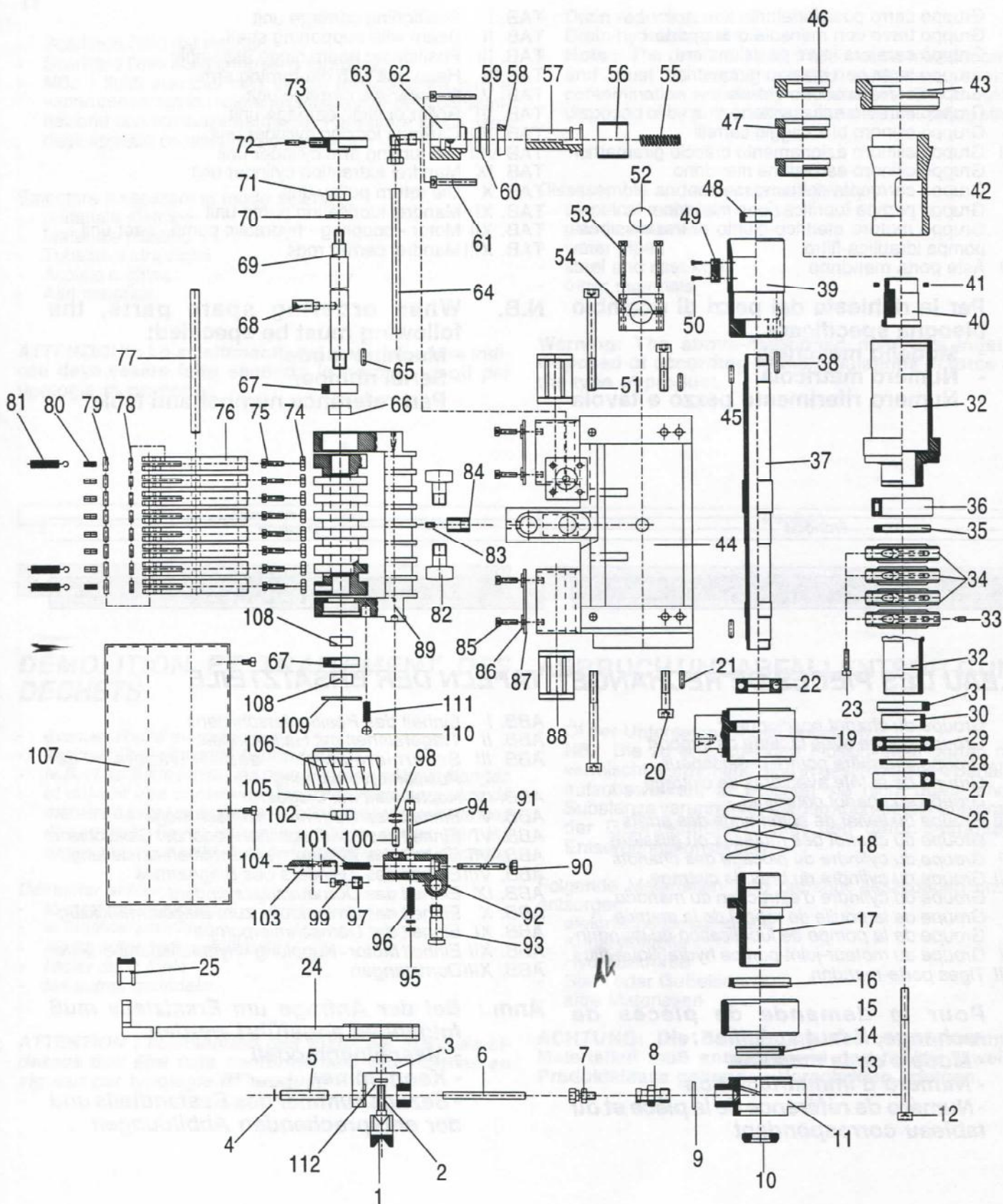

GRUPPO TRAVE CON MENSOLA DI SUPPORTO  
 GROUPE POUTRE AVEC TABLETTE DE SUPPORT  
 BEAM WITH SUPPORTING SHELF  
 TRÄGEREINHEIT MIT HALTEKONSOLE

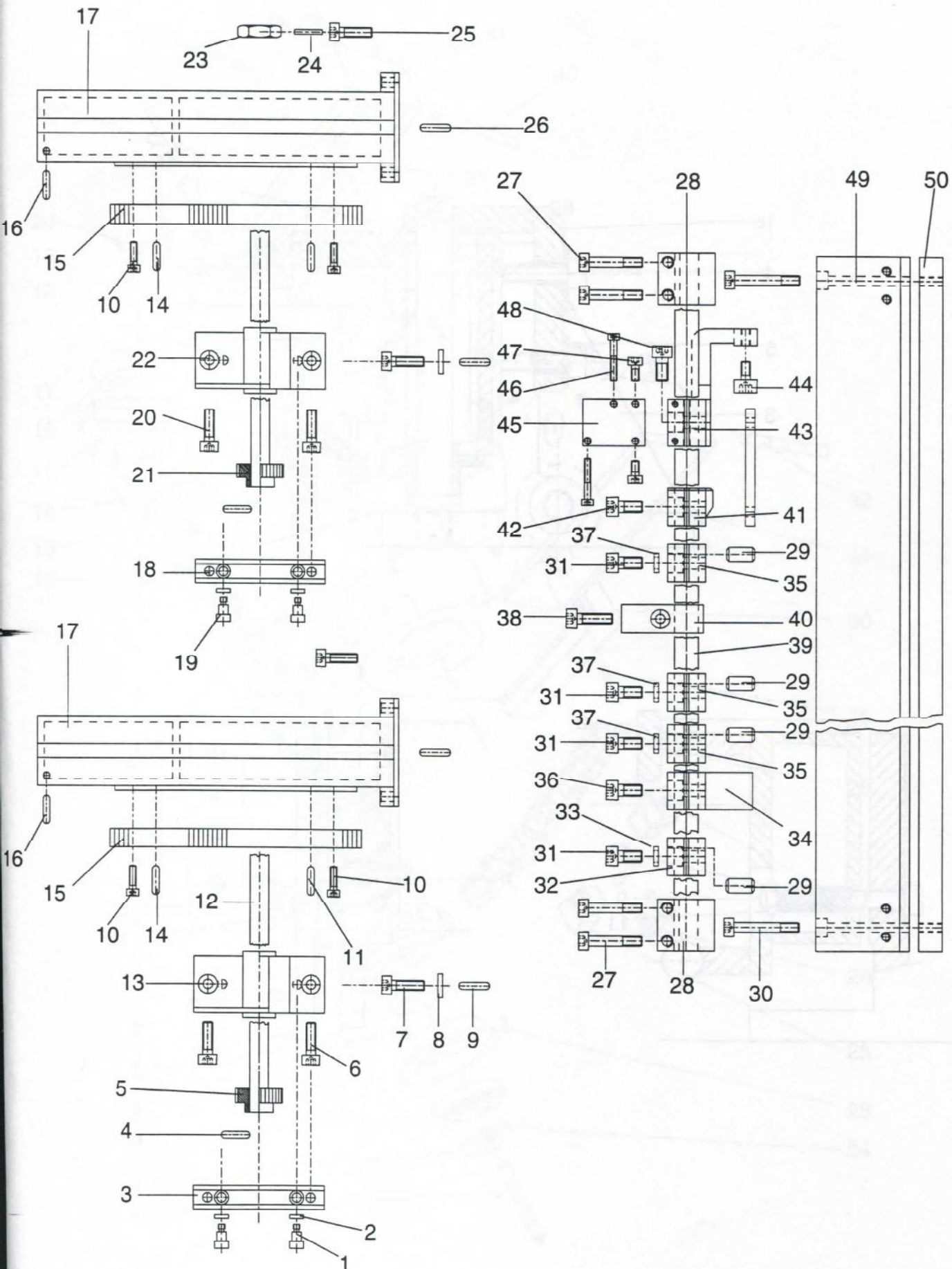



GRUPPO CERNIERA TRAVE POSIZIONATORE  
 GROUPE CHARNIERE POUTRE POSITIONNEUR  
 POSITIONING BEAM HINGE ASSEMBLY  
 SCHARNIEREINHEIT DES TRÄGERS DER POSITIONIERVORRICHTUNG

